



Instruction Manual



Hot Food Merchandiser (HFMV)







Thank you for purchasing this King Edward product, it has been hand built in the UK, using high quality components combined with traditional styling. This instruction manual will help you get the best out of your purchase. We recommend you make a note of your serial number in case you need it for future reference.

If sold to non UK markets, these instructions can be provided in the appropriate language if required.

Serial Number

Despatch Date

Contents

	Packaging.....	3
	Installation	3
	Health & Safety.....	3
	Cleaning & Maintenance	3
	Instructions for Use.....	5
	Changing the Oven Bulb.....	5
	Wiring Instructions for UK Plug.....	5
	Hot Food Merchandiser: Parts Diagram & List.....	6
	Hot Food Merchandiser: Wiring Diagram.....	7
	Trouble Shooting.....	8
	Warranty.....	8
	EU Declaration of Conformity.....	9

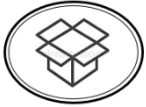

Packaging

The packaging your product was delivered in can all be recycled. Please dispose of it responsibly with consideration for the environment. Remove all packaging from inside and outside of the unit before connecting it to the electricity supply.



Installation

- Choose a stable flat work surface with a weight bearing capacity suitable for the product you have purchased.
- The exterior of this appliance will get warm during operation
- You will require a suitable 220-240 volt 13amp socket to plug your appliance in.
- Do not use a multi adaptor to share this socket as electrical overloading may occur.
- Do not trap the mains flex under the appliance or place it next to hot surfaces, damage to flex is not covered by warranty.
- If the mains flex is damaged, it must be replaced by the manufacturer, their service agent, or a similarly qualified person.



Health & Safety

When using this equipment it is important that you apply industry recognised Health and Safety procedures for electrical cooking equipment and the handling and serving of hot food.

- Always use an oven glove or gauntlet when removing any type of hot food from this unit.
- Under NO circumstances should children come into contact with or operate this appliance.
- Avoid opening the warmer door unnecessarily as this will lower the internal temperature of the display unit,
- Follow recommended storing temperatures for the food stuff being kept warm



Cleaning & Maintenance

Cleaning your display unit on a daily basis will help maintain its good looks and prevent stains from setting in.

1. Always allow the unit to cool and disconnect the display at the socket before cleaning.
2. Clean the exterior and interior with warm soapy water and a cloth. Do not use abrasive materials or cleaners on any parts of the unit.
3. Quality oven clearer can be used to clean the stainless steel interior of the unit.

4. Do not submerge this warmer in water or use any water jets to clean it.



Instructions for Use

1. Plug the merchandiser in and turn the control dial so the required temperature is in line with the neon light.
2. When the red neon light goes off the required temperature has been achieved. You can then load the **pre-heated** foodstuff. This unit is not intended to cook food or heat food from cold.

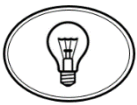

Changing the Oven Bulb

This warmer uses a push-in G9 25 watt, 240volt halogen capsule lamp, these can be readily obtained from most DIY stores. Bulbs are not covered by guarantee.

1. Disconnect the warmer from the electrical supply.
2. Carefully unscrew the glass bulb cover (top lamp) or pull off the glass cover (side lamps) from inside the warmer.
3. Remove the old bulb by pulling away from the connection end.
4. Do not touch the new bulb with bare hands, if touched, wipe clean with a cloth and methylated spirit.
5. Replace the new bulb by pushing prongs into the relevant holes and reattach the glass lens.

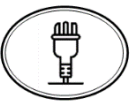

Wiring Instructions for UK Plug

This appliance must be earthed, any work carried out must be done by a qualified electrician.

1. Prepare all 3 wires by stripping back silicone to expose 8mm of bare wire
2. Loosen cord grip
3. Wire in the sequence: Neutral – Live – Earth
4. Ensure terminal screws are tight
5. Always use 13 amp (Brown) fuse
6. Tighten cord grip onto cord before replacing cover

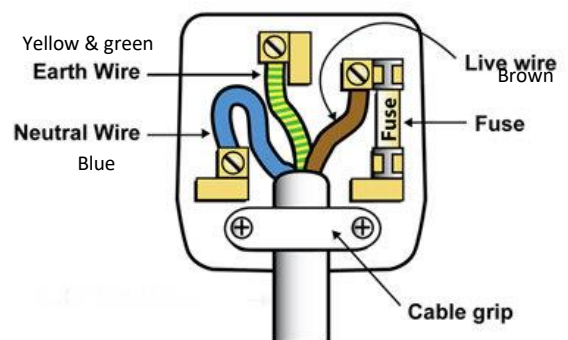

Hot Food Merchandiser: Parts Diagram & List

HFMV – 39Kgs

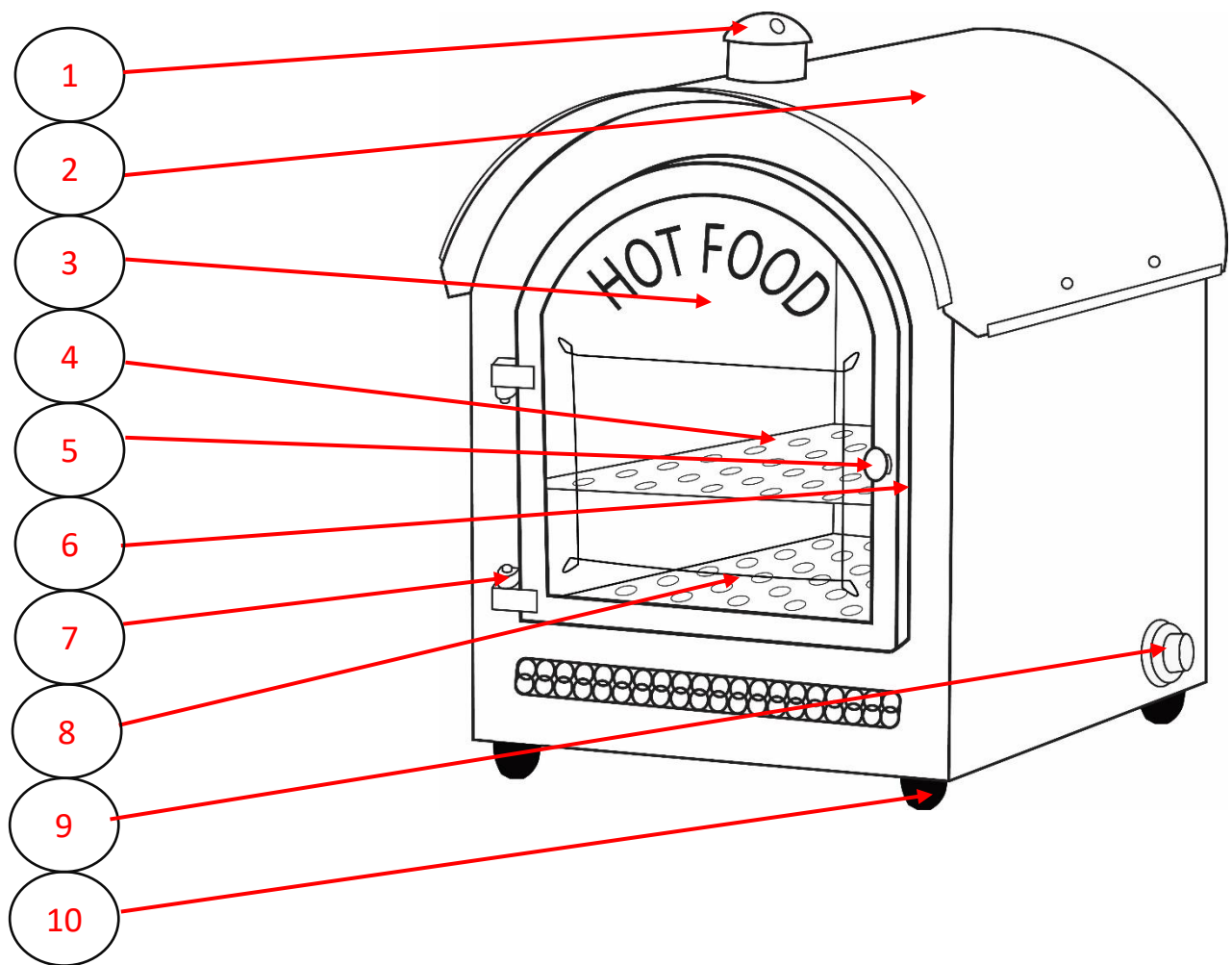

Product Description

Part Number

1.	Brass chimney dome	700108
2.	Canopy with brass trim (please state colour)	600105
3.	Door assembly (2 per unit) including glass	HFMV-DA
4.	Display tray (3 per unit)	500140
5.	Door Handle (2per unit)	500221
6.	Magnetic door catch (2 per unit)	500128
7.	Door Hinge Pins	700122
8.	Element cover	HFMV-EC
9.	Control Knob	190304
10.	Oven Feet (Set Of 4)	C-RF

Hot Food Merchandiser: Wiring Diagram

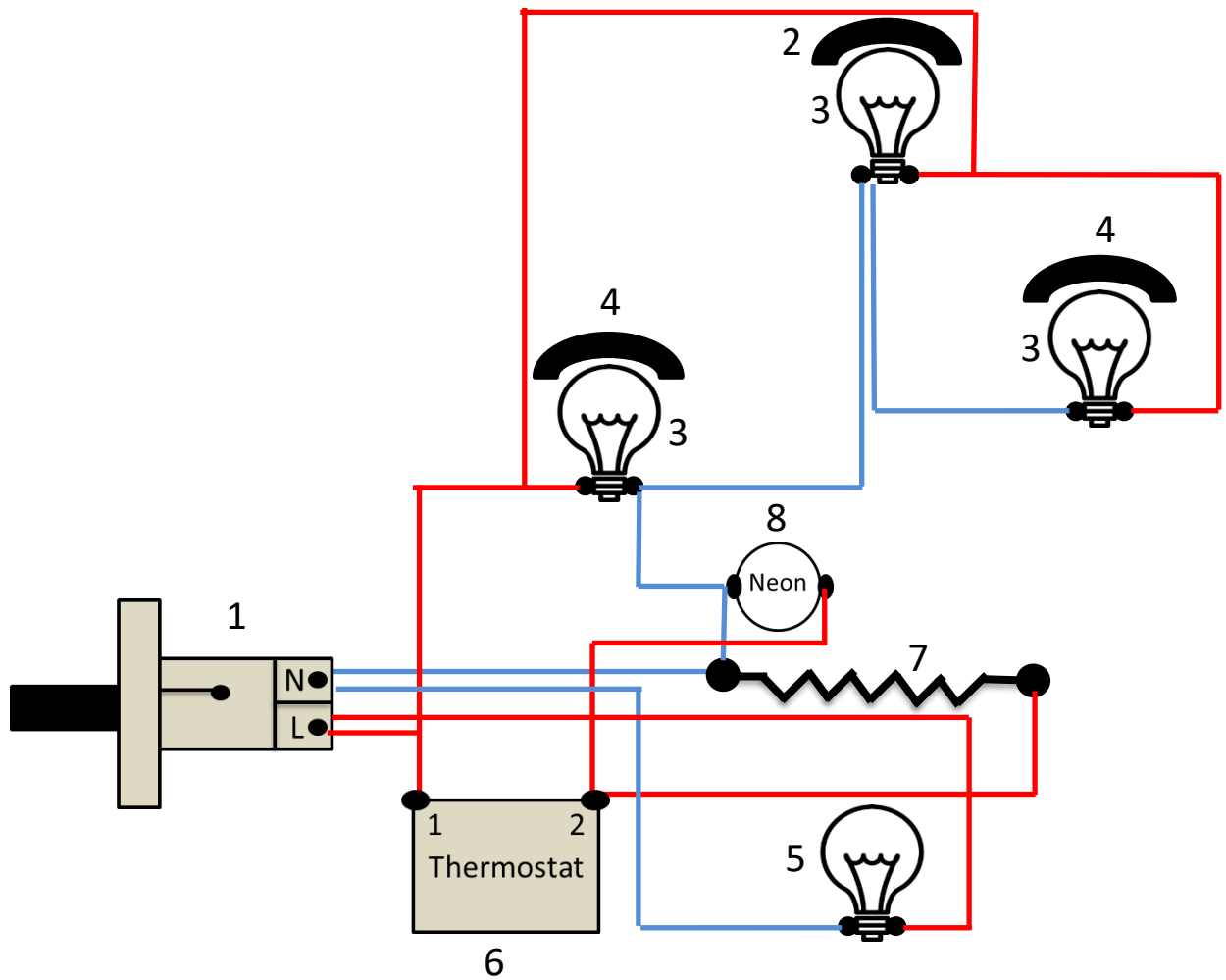

Product description

Part Number

1.	Mains flex	190201
2.	Top light round assembly including lens	700121R
3.	Halogen capsule bulb (3 per unit)	G9400125
4.	Side light square assembly including lens (2 per unit)	700121SQ
5.	Fireglow bulb	190207
6.	Thermostat	190303V
7.	Element	500136
8.	Neon indicator	190305



Trouble Shooting

Please refer to the checklist below before you call your supplier to request a service call. You will be charged for a service call if we find that the equipment is not at fault even if it is still within the guarantee period.

If there is no power to the warmer i.e. lights are not working, element is not heating up, check to see:

1. Is the warmer switched on at the socket?
2. Have you turned the thermometer dial on?
3. Has the fuse blown in the plug?
4. Is the trip on the mains board still on?
5. Has the mains circuit been overloaded?
6. Is the warmer the only piece of equipment using the socket?
7. Is the mains flex damaged?

For any other operating issues, telephone your supplier or King Edward Catering Equipment, we will attempt to assist you over the telephone if we can.



Warranty

- Your unit has a parts guarantee for a period of 1 year for UK purchases, please check with your supplier to confirm if you also have cover for the labour content of any service call, your product invoice may also have this information. The guarantee covers defective parts or workmanship from the time of purchase for a period of 1 year. This does not affect your statutory rights.
- Bulbs, fuses, door seal, damage to mains lead and glass parts are not covered by guarantee. Faults arising from incorrect maintenance or cleaning and the fitting of unspecified parts are also excluded.
- We respond to all service calls promptly but depending on Geographical limits and other limitations beyond our control we may not be able to attend within 24 hours.
- Wherever possible we will attempt to establish the nature of the fault over the telephone and may decide to send parts directly to site.
- In exceptional circumstances we may require the equipment back to our factory for repair, in these cases please allow 4 days from collection to delivery.
- Please ensure that the equipment is completely cooled and in an area where it can be worked on before the engineer's visit.
- At the end of its life this equipment must not be disposed of along with household waste. Its high metal content makes it ideal for recycling and it can be disposed of through a recognised disposal system.

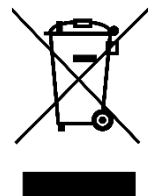

EU Declaration of Conformity

The manufacturer of the products covered by this Declaration is

Monarch Products (Marketing) Ltd
t/a King Edward Catering Equipment
Porthouse Ind Est
Bromyard
Herefordshire
HR7 4NS
oven@kingedward.co.uk

The Directives covered by this Declaration

Low Voltage Directive 2014/35/EU

EMC Directive 2014/30/EU

RoHS Restriction of Hazardous Substances-Directive-2011/65/EU

Waste Electrical and Electronic Equipment Directive-2012/19/EU

The products covered by this Declaration

HFMV



The basis on which Conformity is being declared

The manufacturer hereby declares under his sole responsibility that the products identified above comply with the protection requirements of the EMC and LVD directives and that the following standards have been applied:

EN 60335-1:2012 + AC:2014 + A11:2014
EN 60335-2-42:2003 + A11:2012/BS EN60335-2-42:2003+A11:2012

The technical documentation required to demonstrate that the product meets the requirements of EMC and LVD directives has been compiled and is available for inspection by the relevant enforcement authorities.

Signed:

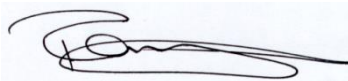

Paul Wrighton, Managing Director

Date:

01/01/2018

The attention of the specifier, purchaser installer or user is drawn to special measures and limitations to use which must be observed when these products are taken into service to maintain compliance with the above directives. Details of these special measures and limitations to use are available on request and also contained in product manuals.

As A small independent manufacturer we can often adapt our designs and finished to suit specific requirements, please contact us if you would like to find out more about what we can do.



King Edward Catering Equipment
Porthouse Industrial Estate, Bromyard, Herefordshire, HR7 4NS

01885 489200
oven@kingedward.co.uk
www.kingedward.co.uk